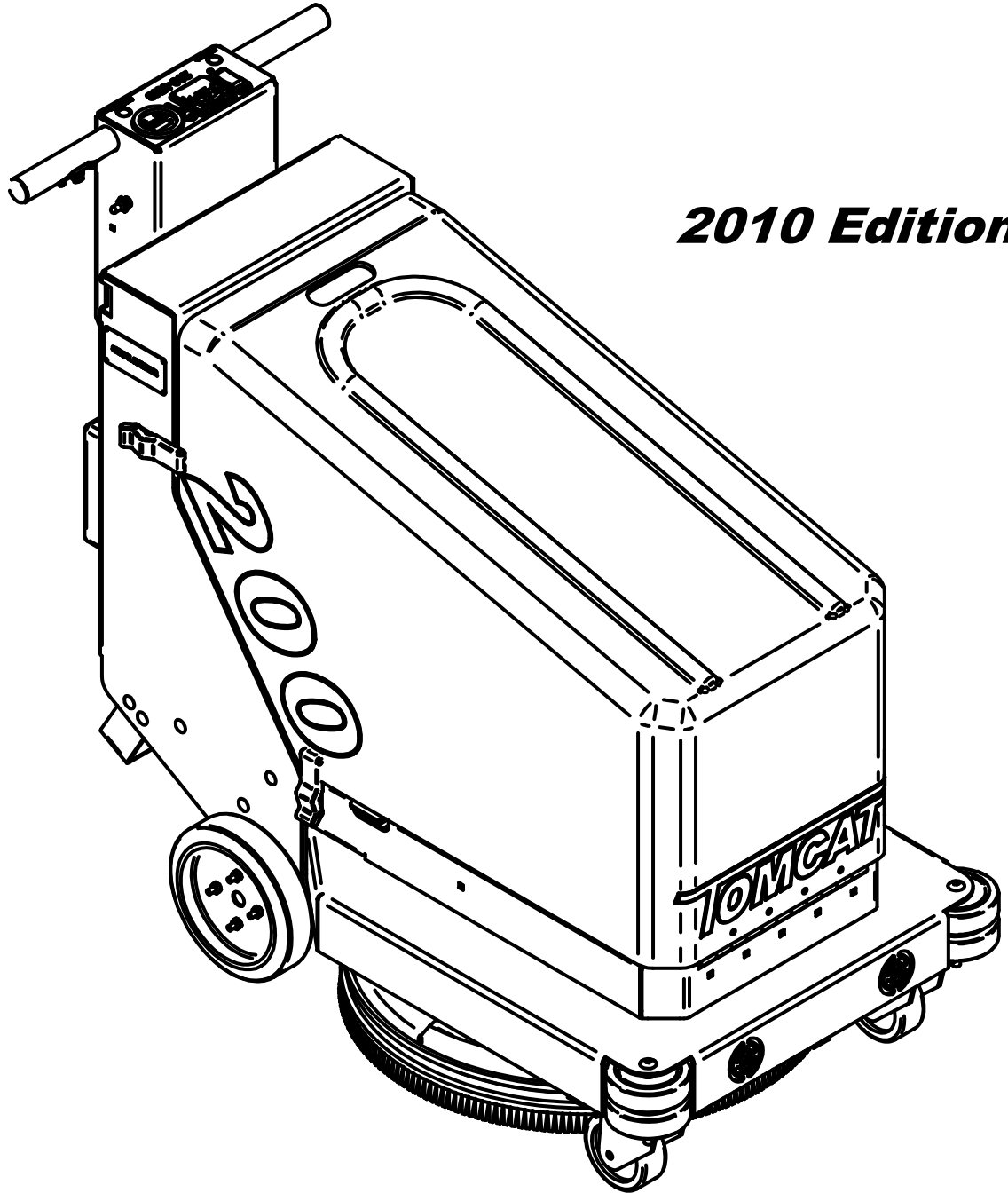


200 Burnisher

Model 200

Operator Manual *200 Walkie Burnisher*



2010 Edition: 1

R.P.S. Corporation
P.O. Box 241
Racine, Wisconsin 53401

Phone: 1-800-450-9824
Fax: 1-866-632-6961

How to use this manual

This manual contains the following sections:

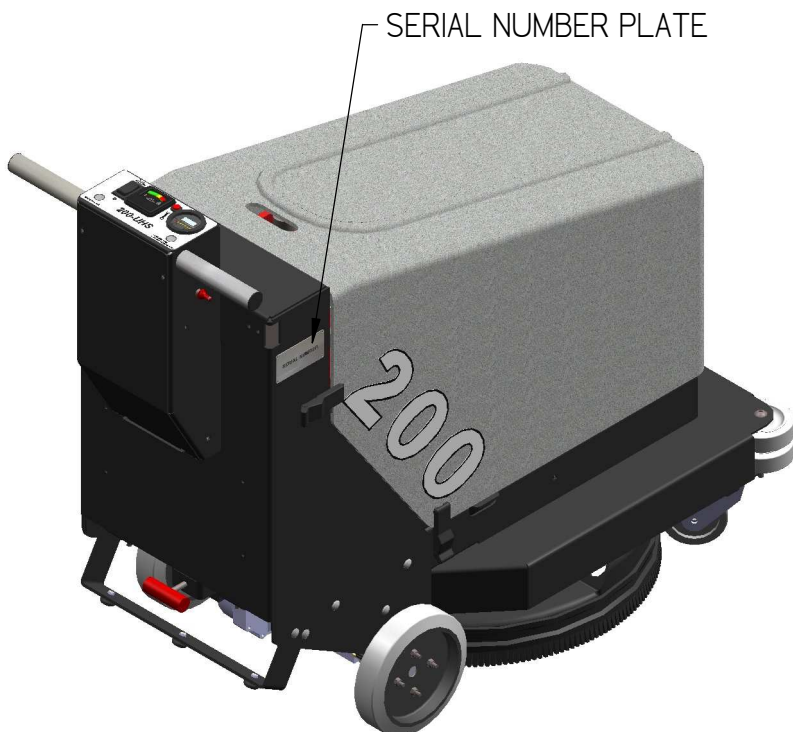
- **HOW TO USE THIS MANUAL**
- **SAFETY**
- **OPERATIONS**
- **MAINTENANCE**
- **PARTS LIST**

The **HOW TO USE THIS MANUAL** section will tell you how to find important information for ordering the correct replacement parts.

Parts may be ordered from authorized dealers. When placing an order for parts, the machine model and serial number are important.

Refer to **MACHINE INFORMATION** on page one of this manual, which is filled out during the installation of your machine.

The serial number of your machine is located on the lower half of steering tower of the machine. **(See Picture Below)**



The **SAFETY** section contains important information regarding hazard or unsafe practices of the machine.

Levels of hazards are identified that could result in product or personal injury, or severe injury resulting in death.

The **OPERATIONS** section is to familiarize the operator with the operation and function of the machine.

The **MAINTENANCE** section contains preventative maintenance information to keep the machine and its components in good working condition. They are listed in this general order:

- Batteries
- Burnishing Pads
- Cleaning Filter
- Service Schedule
- Machine Trouble Shooting

The **PARTS LIST** section contains assembled parts illustrations and corresponding parts list. The parts lists include the following columns of information:

- **ITEM** - Refers to the reference number on the parts illustration.
- **PART NO.** - Lists the part number for the part.
- **QTY** - Lists the quantity of the part used in that area of the machine.
- **DESCRIPTION** - Is a brief description of the part.
- **COMMENTS** - For information not noted by the other columns.

NOTE: If a service or option kit is installed on your machine, be sure to keep the **KIT INSTRUCTIONS** which came with the kit. It contains replacement part numbers needed for ordering future parts.

Table of contents

Machine information form	Page 1
Warranty registration form	Page 2
Machine specifications	Page 3
Common wear parts	Page 4
Safety messages	Page 5
!!Safety precautions!!	Page 6
Machine controls and features	Page 7
Controls and fuctions	Page 8
Machine preparation	Page 9
Machine setup	Page 10
Operation	Page 11
Pre-burnishing check list	Page 11
One pass burnishing	Page 11
Charging batteries	Page 12
Onboard charger	Page 13-14
Maintenance	Page 15
Preventative maintenance records	Page 16-17
Troubleshooting	Page 18-19
Machine parts section	Page 20-32

Machine Parts Illustration

Machine Bottom Components	Pages 21-22
Burnisher Deck	Pages 23-24
Actuator Slide	Pages 25-26
Machine Top Components	Pages 27-28
Central Command	Pages 29-30
Handle Bar	Pages 31-32

Machine information

Please fill this area out at the time of installation for future reference.

Model number _____

Serial number: _____

Installation date: _____

Installing dealer: _____

Dealer contact: _____

Address: _____

City, state, zip: _____

Phone number: _____

This operator and parts manual should be considered a permanent part of the unit and should remain with the unit at all times. This operator and parts manual covers all the Tomcat 200 Series burnishers. You may find descriptions and features that are not on your particular model. The information and specification included in this publication were in effect at the time of printing. R.P.S. Corporation reserves the right to make changes without notice incurring any obligation.

To register for warranty, fax your warranty registration form today!

Common wear parts

<u>Pad</u>	<u>Pad Function</u>	<u>Results</u>	<u>200 Part Number</u>
Image ultra high speed - beige	Ultra high speed High speed buffing And burnishing.	For high speed buffing and burnishing. For frequent burnishing on soft to medium finishes.	20-4221
Luster lite - blue	Ultra high speed buffing and burnishing.	For burnishing soft floor finishes. May be used on a daily basis. Ideally suited for top dressing highly polished floors.	20-4222
Combo ultra high speed	Ultra high speed buffing and burnishing.	Blended polyester and natural fibers. For frequent burnishing on medium finishes.	20-4223
Porko ultra high speed	Ultra high speed buffing and burnishing.	Blended natural fiber pad. For frequent minimal burnishing on hard finishes.	20-4224
Porko elite	Ultra high speed buffing and burnishing.	Blended natural fiber pad works on all UHS machines. For minimal burnishing on medium to hard finishes.	20-4225
Porko plus	Ultra high speed buffing and burnishing.	High content of natural fibers. Ideal for minimal burnishing on hard finishes.	20-4226

Safety Messages

Your safety, and the safety of others, is very important and operating this unit safely is an important responsibility.

To help you make informed decisions about safety, we have provided operating procedures and other safety information in this manual. This information informs you of potential hazards that could hurt you or others.

It is not practical or possible to warn you of all the hazards associated with operating this unit. You must use your own good judgment.

This is intended for commercial use. It is designed to be used on hard floors in an indoor environment, with the recommended pads.

1. DO NOT OPERATE UNIT:

Unless trained and authorized.
Unless operator manual is read and understood.
If unit is not in proper operating condition.

2. WHEN OPERATING UNIT:

Remove loose objects from the floor that may be projected from the revolving burnisher pad.
Keep hands and feet away from revolving pads.
Do not operate machine where flammable liquids or gasses are present.
Use extreme caution when maneuvering.

3. BEFORE LEAVING:

Make sure machine is turned off.
Stop on level surfaces.

4. BEFORE SERVICING:

Stop on level surface, and secure machine.
Disconnect batteries.

!! Safety Precaution!!

WARNING: Hazardous voltage. Shock, burns or electrocution can result. Always disconnect the batteries before servicing machine.

WARNING: Batteries emit hydrogen gases. Explosion or fire can result. Keep sparks and open flames away.

WARNING: Charge unit in a well ventilated area, and keep battery compartment open when charging. Explosion or fire could result.

WARNING: Battery acid can cause burns. Wear protective eye wear and gloves when servicing batteries.

WARNING: Do not store outdoors or pressure wash. Prevent electronic components from getting wet.

WARNING: The use of parts and solutions other than that recommended by the manufacturer may cause damage or endanger people.

WARNING: Dress safely. Do not wear rings or metal wrist watches while working on this machine. They can cause an electrical short, which, can cause serious burns. Do not work on this machine while wearing a tie, scarf or other loose, dangling neckware or clothing. These loose items can tangle in the rotating parts and cause serious injury or even death.

WARNING: Do not use the machine as a step ladder or chair.

WARNING: Only operate this machine from the operators position. It was not designed to carry passengers.

WARNING: Do not operate this machine on ramps or uneven surfaces. When climbing a ramp, always drive the machine in forward straight up or down the ramp. Never drive across the incline. Do not back down or turn on ramps!

WARNING: Always use the charger provided by the manufacturer to charge the machine. It is an automatic charger, specifically designed to charge at the appropriate rate. If you must use a different charger, disconnect the batteries before charging. This will prevent damage to the electronic speed controller.

WARNING: Do not park the machine on ramps or slopes.

WARNING: Do not operate the machine if any parts have been removed or damaged.

WARNING: Do not remove, paint over, or destroy warning decals. If warning decals become damaged, they must be replaced.

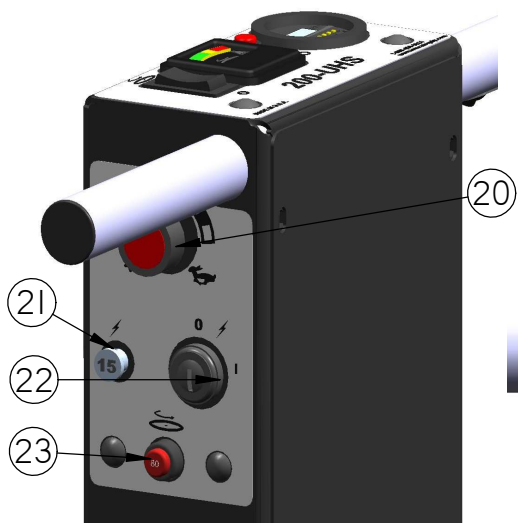
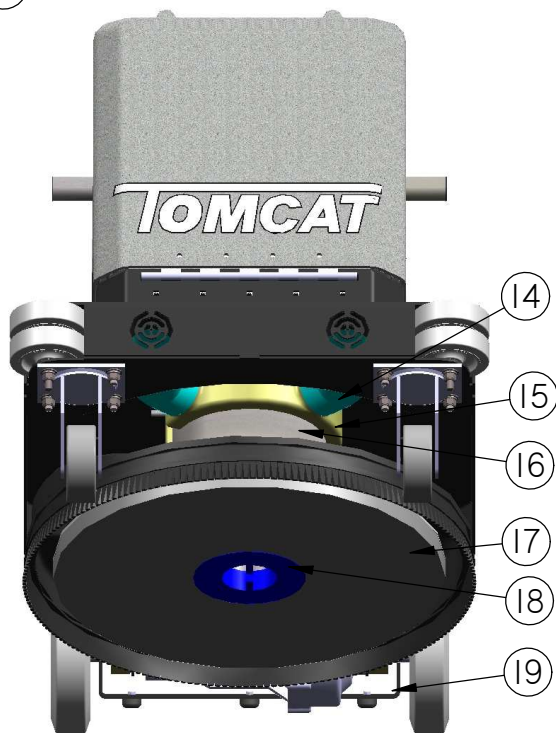
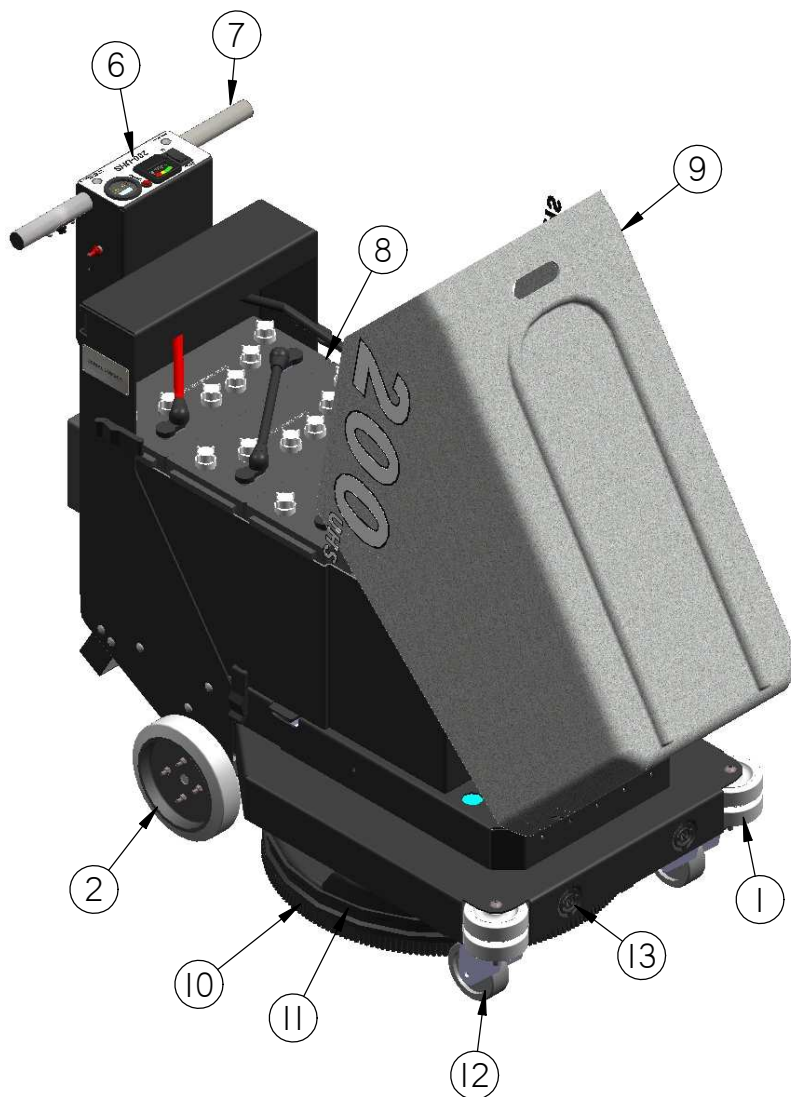
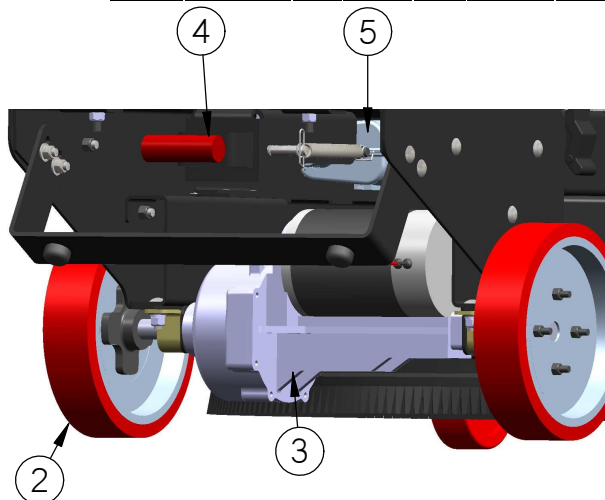
WARNING: Do not operate machine in unsafe condition. If the machine is in need of repair or is in any way unsafe to operate, the matter should be reported immediately to the shift supervisor. Do not operate the machine until it is returned to proper operating condition.

WARNING: This machine must only be operated by trained operator. As part of his or her training, they must read this manual thoroughly. If extra copies are needed, contact your local dealer.

WARNING: Always turn off the machine, before leaving it unattended.

WARNING: Do not operate over electrical floor outlets. May result in serious injury.

Machine Controls and Features



Controls and Functions

See figures (1-6) on page 7

1. **Corner roller bumpers:** helps prevent damage to machine when cleaning close to walls and other objects.
2. **Rear tires:** Non-marking and extra wide tires for stability.
3. **Rear transaxle:** Provides propulsion for machine.
4. **Spring adjustment knob:** Increases or decreases the pad pressure.
5. **Actuator:** The actuator lifts and lowers the deck.

6. **Central command box:** Holds all electrical switches and control components.
7. **Handle bar:** Used to steer the machine.
8. **Batteries:** The machine comes standard with (3) 12 volt batteries (**Standard**) or (**Optional**) (6) 6 volt batteries
9. **Battery access lid:** Provides access to batteries for charging and maintenance.
10. **Shroud:** The shroud contains dust created from burnishing.
11. **Shroud curtain:** The shroud curtain contains dust created from burnishing.
12. **Casters:** Twin casters for stability.
13. **Clean air intake:** The clean air intake allows clean air to flow into the burnishing motor.

14. **Clean air intake hoses:** The clean air intake hoses direct clean air into the burnishing motor.
15. **Burnisher motor cover:** Prevents dust from entering the burnisher motor prolonging motor life.
16. **Burnisher motor:** This motor drives the burnishing pad driver.
17. **Burnisher pad:** Burnishes floor
18. **Pad retainer clip:** Holds burnisher pad to pad driver.
19. **Tip back bar:** The machine tips back to allow easy access to burnisher pad installment and removal

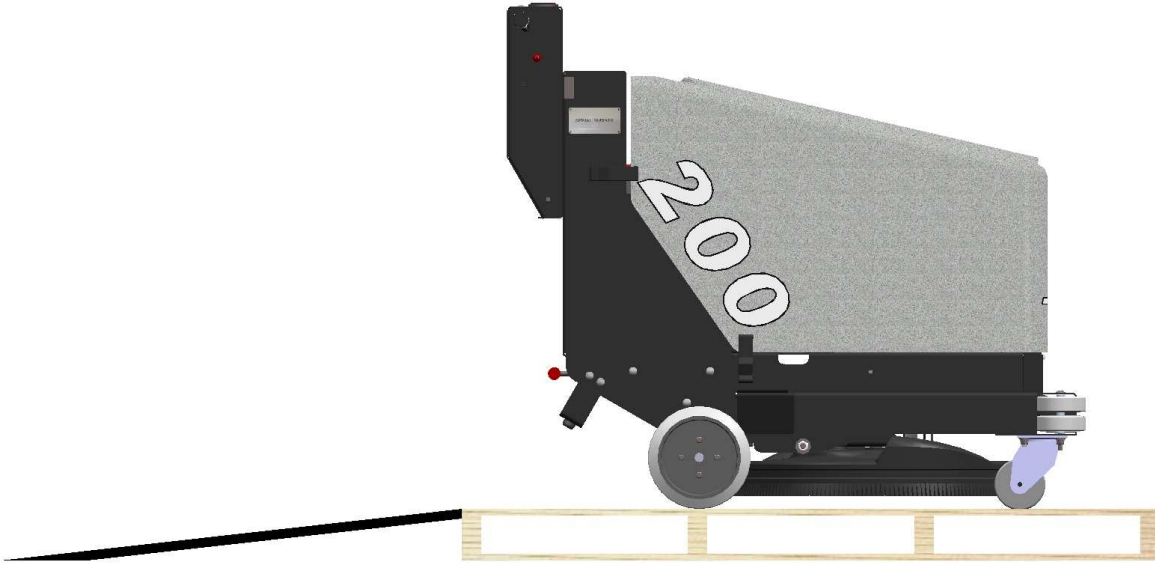
20. **Speed control knob:** Controls the drive speed of the machine, turn clockwise to increase speed and counter clockwise to decrease speed.
21. **(+) 15 amp resetable circuit breaker:** (15 amp) positive bus bar.
22. **Key switch:** Turns power to machine on and off.
23. **Resetable 65 amp burnisher motor circuit breaker:** Prevents motor damage do to too much down pressure

24. **Burnisher deck switch:** Lowers burnisher deck.
25. **Burnishing deck pressure gauge:** Settings green (safe operating range) - red (overload).
26. **Burnishing motor brush indicator:** Indicates when the burnisher motor needs new brushes.
27. **Hour meter:** Keeps track of how many hours are on the machine.
28. **Battery gauge:** Indicates relative battery charge remaining.
29. **Reverse switch:** Controls the direction of the traction motor.
30. **Green control button:** Depress to drive the machine forward and release to stop

Machine Preperation

Uncrating machine

Carefully check the crate for any sign of Damage. Batteries are in the unit. To uncrate the machine, remove banding from around the crate. Take off the top and sides And dispose of properly. Remove banding from machine. Remove the chocks around the drive wheels. Fold down ramp, and roll machine off of the base. Notify the carrier immediately if concealed damage is discovered.

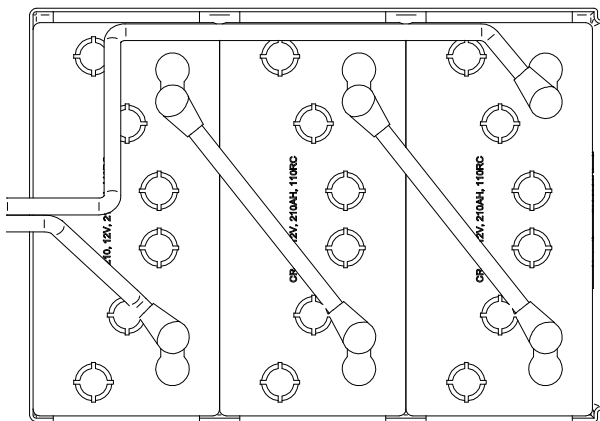


Connecting batteries

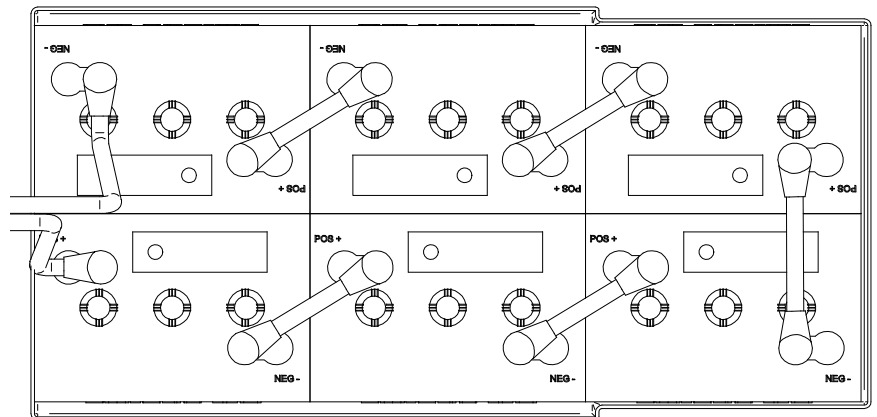
Your machine is equipped with (3) 12 volt, Deep cycle 175, amp hour batteries or, an optional (six) 6 volt, Deep cycle, 245 amp hours batteries, which Form a 36 volt system.

1. Turn all switches to the off position and remove key.
2. Hinge open the battery access lid to access the battery compartment.
3. All of the battery cables are connected to the batteries. Locate any loose ones and connect to the open terminal. Tighten with 9/16" wrench. **(see below)**
4. Turn on main power switch and check the battery condition meter to ensure correct installation. Charge batteries if needed. **(see: battery charging)**

Standard (3) 12-volt 175 ah



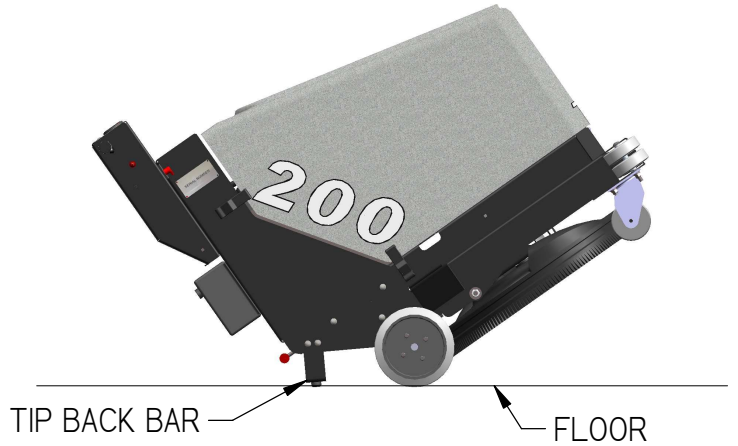
Optional (6) 6-volt 245 ah



MACHINE SETUP

ATTACHING PAD

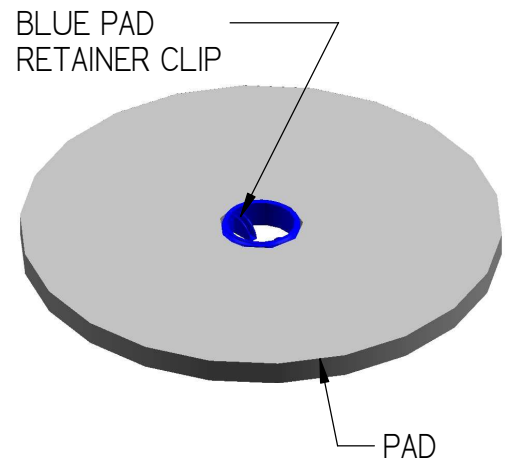
1. Turn machine power off.
2. Tip machine back until the tip back bar is resting safely on floor.



3. Remove blue pad retainer clip from pad holder.



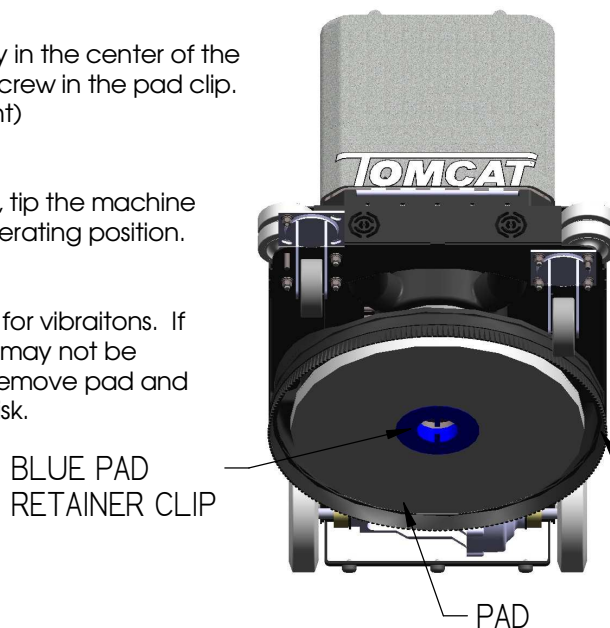
4. Place pad on top of locking clip and slide both below burnishing deck directly into the center of the burnishing disk. **(see right)**



5. With pad and clip directly in the center of the burnishing disk push up and screw in the pad clip. (Hand tighten only) (see right)

6. Once the pad is in place, tip the machine back down to the normal operating position.

7. Run machine and check for vibrations. If deck vibrates badly the pad may not be centered on disk correctly. Remove pad and reinstall pad in the center of disk.



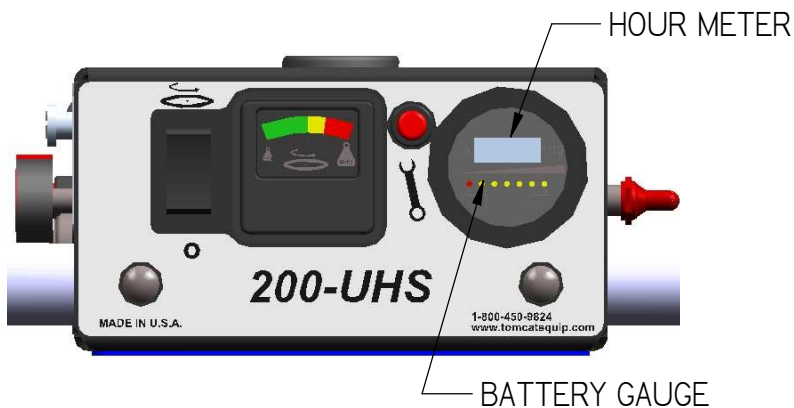
SHROUD AND SHROUD CURTAIN
FOR CORRECT PAD APPLICATION, CALL YOUR LOCAL DEALER

Operation

Read and understand the safety section on page 5 and 6 before operating machine.

Pre- burnishing Check list

1. Check battery condition gauge on the hour meter/battery gauge. **(See below)** Make sure batteries are fully charged before using.



2. Check condition of pad and make sure it is securely in place.

3. Check hose connections from the motor to the frame are secure. **(See below)**

5. Check condition of shroud curtain the shroud curtain needs to be in good condition for dust control system to work properly. **(See below)**



Operating hints

One Pass Burnishing

Steps: (see below)

1. Turn machine on with the key switch.

2. Lower burnishing head to the floor by simply depressing the black burnisher deck button.

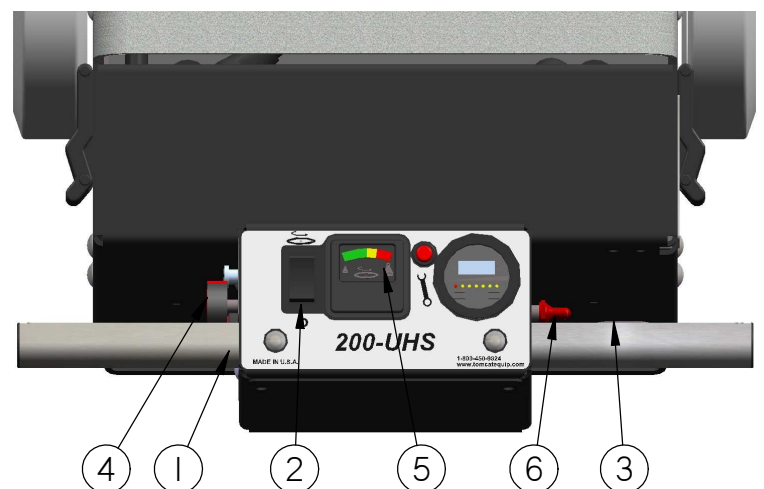
3. Begin burnishing by holding the green control button on the handle bar.

4. Adjust the red speed control knob to desired speed located on the side of the central command box.

5. Once the pad begins to move, check the pressure gauge. Start burnishing with in the green marks, do not use yellow marks without management approval.

6. To operate machine in reverse, simply pull back on red togel switch located on the right hand side of central command box.

7. To stop the machine, let go of the green control button and the machine will stop automatically.



Battery charging

CAUTION: The following instructions are intended for the 36v charger supplied with the machine. Do not use any other charger with this machine.

Charger specifications

Output voltage of 36 volts.

Output current of 25 amps max.

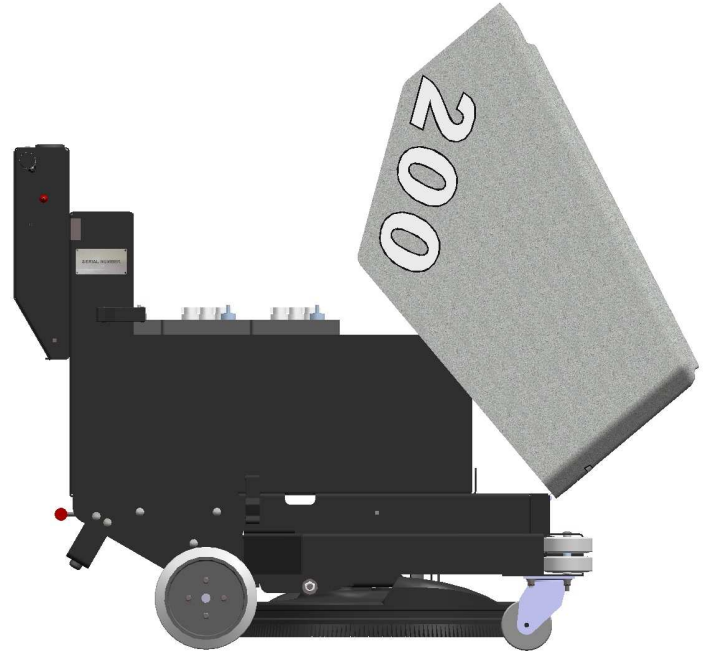
Input voltage of 110 volts/60 Hz.

Automatic shut off circuit.

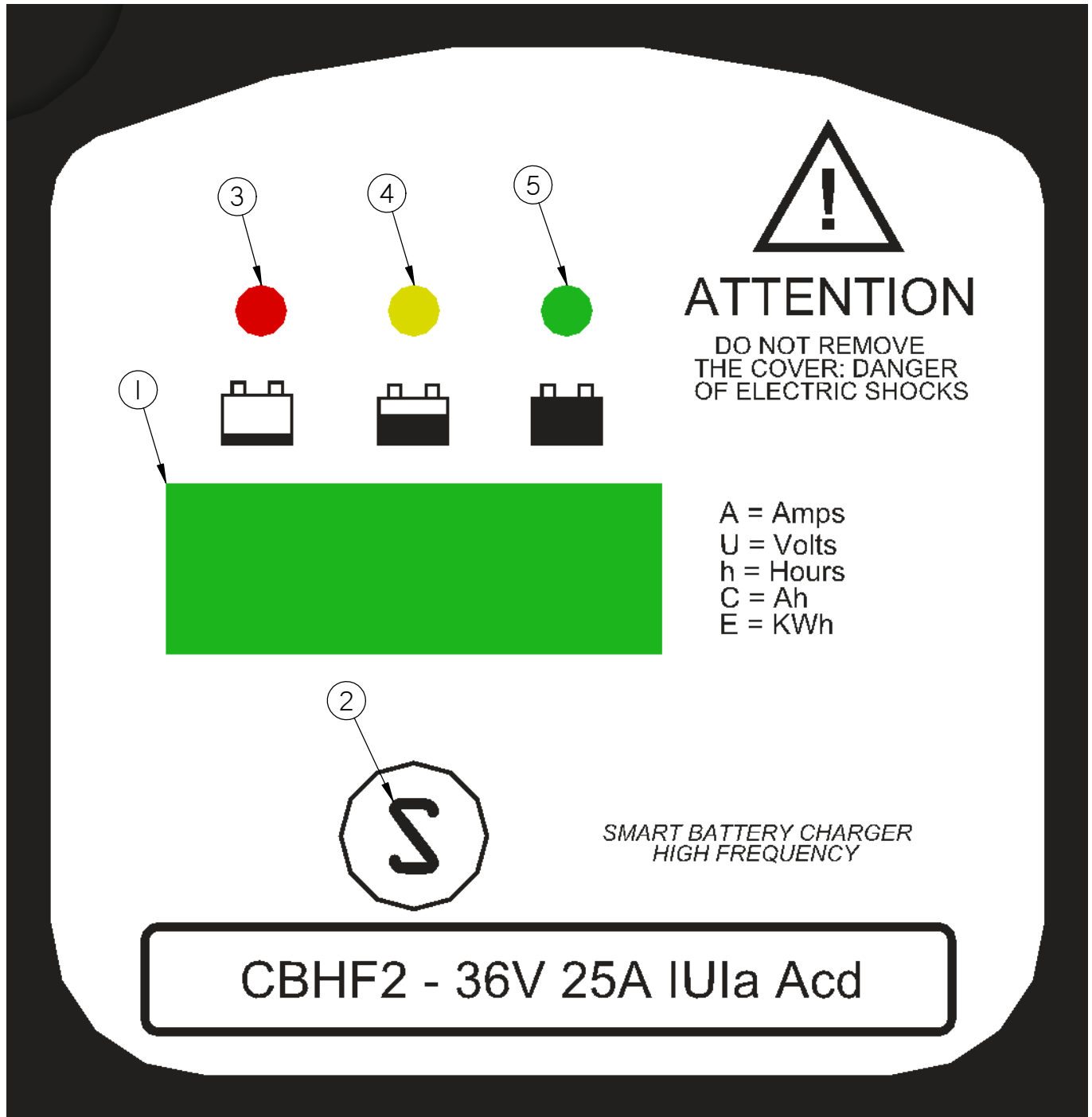
Made for deep cycle batteries.

Danger: always charge batteries in a well ventilated area. Batteries emit hydrogen gas. Explosion or fire can result. Keep sparks and flame away. Shield eyes when servicing batteries and avoid contact with battery acid. **Leave rear hood open when charging!**

1. Transport machine to a well ventilated area for charging.
2. Turn the machine off.
3. Hinge opens the battery access hood to expose the batteries. (Caution: always wear eye protection when batteries are exposed)
4. Check the water level in each battery. Do not charge the machine unless the water is slightly higher than the plates. If needed, add enough distilled water to just slightly cover the plates. Do not over fill. Batteries can overflow during charging. Replace caps before charging.
5. With the grey charger plug disconnected from the machine, plug the charger power cord into a grounded 110 volt standard wall outlet.
6. Connect the grey charger plug into the battery charging port located on the lower portion of the steering tower.
7. The charger will automatically begin charging, and automatically shut off when fully charged (check gauge)
8. After the charger has turned off, unplug the grey charger plug from the machine and disconnect the charger from the wall outlet.
9. Recheck the cell level after charging. If needed, add distilled water up to the correct level. Be certain to replace the caps securely and to wipe off the top of the batteries with a clean cloth.



Onboard battery charger display



Onboard battery charger display

General information and warnings

Electronic automatic battery charger with microprocessor suitable for any battery type.

Fully automatic charging cycle with electronic setting protected against overload, short-circuit at clamps and reversed polarity.

Never disconnect the battery while charging: this could cause sparks.

Never use the equipment in the rain, in areas used for washing or damp areas.

Before starting to charge, make sure the voltage of the equipment suits the voltage of the battery, that the charging current suits the capacity of the battery and the selected charging curve (for lead-acid batteries or airtight gel batteries) is correct for the type of battery to be charged. In addition, make sure the rated input voltage of the charger suits the available supply voltage and the system is equipped with grounding.

If necessary, replace the fuse with another of the same type and value as indicated on the rating plate.

Use battery chargers only in well ventilated areas.

Pay attention to any remarks on the battery manufacturer.

For lead-acid batteries with liquid electrolyte:

Control the water level after each charging process.

Refill with distilled water only.

Caution! The gasses generated during charging are explosive. Do not smoke in the vicinity of the batteries. When working with cables and electrical equipment, avoid open flames and sparks.

Attention: Use protective glasses and gloves during battery maintenance. Battery acid causes injuries. In case of contact with battery acid, wash the affected parts with a lot of fresh water and consult a doctor if necessary.

Controls

1. Three-digit display + symbol (1), to view A = the charging current, U = the battery voltage, h = the charging time, C = the charging ampere-hours (Ah), e = the energy used (KWh).

2. Button for the selection of the display mode (2): A, U, h, C, E. After about 10 seconds the display returns to the visualization of the charging current.

3. Red control indicator (3): when it is on, the charging cycle has started.

4. Yellow control indicator (4): when it is on, the final phase of the charging cycle as started.

5. Green control indicator (5): when it is on, the charging cycle has finished.

Operation

Plug the cord into a socket.

Connect the battery, checking the polarity.

Now, the battery charger display will show a sequence of details on the charger's internal programming: after the name "SPE", it will show the software release installed in the equipment, then in sequence, the following parameters: battery voltage, charging current, charging curve number and, finally, the words "GEL" or "ACD" depending on the set up charging curve being suitable for airtight gel batteries or lead acid batteries. **Make sure the type of batteries to be charged (gel or lead-acid batteries) matches the displayed details ("GEL" or "ACD", respectively). If it doesn't, contact our dealer.** Now a test is run on the battery voltage to decide if the charging process should be started or not. If the battery is not connected to the battery charger, the display will show the word "BAT". The word will stay on, even if the test is failed (for instance, reversed polarities or incorrect battery connection). If the test is passed, the display will show the battery voltage for approximately 5 seconds and the battery will begin to be charged. The charging cycle progress will be shown by red (3), yellow (4) and green (5) LED indicators. At the end of the charge, when the green indicator (5) is on, unplug the cord from the socket and operate the machine.

Problems	Solutions and checks
The battery charger does not switch on.	Check that the plug is connected to the supply mains and that the fuse is efficient
The charging cycle does not start and the message "bat" is displayed.	Check the connection to the battery and the polarity.
The yellow indicator (4) will not light up even 15 hours from the starting of the charging cycle, and the display	Check the battery for possible faulty components.
The message E01 is displayed	This means that the maximum voltage admissible by the battery has been exceeded. The charging is interrupted.
If the battery charger is provided with a safety thermostat and the message E02 is displayed.	This means that the maximum temperature has been exceeded. The charging is interrupted.
The message E03 is displayed	This means that the maximum time for the charging phase has been exceeded. The charging is interrupted.
The message Sct is displayed	This means that the total safety timer has interrupted the
The message Srt is displayed	This signals a possible internal short circuit.

Maintenance

Daily Maintenance

1. Check pad condition. (Replace if necessary)
2. Check battery charge.
3. Clean dust control filters.
4. Check hoses and verify there are no clogs.
5. Check pads for wear and replace if needed.
6. Charge unit and verify that charger is operating properly

Monthly Maintenance

1. Check flex driver
2. Check to see if battery cables are tightened and clean. (Tighten if needed)
3. Check condition of burnishing deck actuator.

Weekly Maintenance

1. Check battery water level.
2. Check condition of all three tires.
3. Check condition of dust curtains on shroud.
4. Check condition of dust control hoses.
5. Check to see if vacuum exhaust is clear.

Yearly Maintenance

1. Call your local dealer for yearly maintenance

Preventative maintenance records

CUSTOMER INFORMATION							
CUSTOMER							
ADDRESS							
CITY				STATE		ZIP CODE	
MACHINE INFORMATION							
MODEL #				SERIAL #			
WORK ORDER#				HOUR METER:			
BATTERY CONDITION		Cell #1	Cell #2	Cell #3			
Battery # 1 Hydrometer Reading							
Battery # 1 Water Condition							
Battery # 2 Hydrometer Reading							
Battery # 2 Water condition							
Battery # 3 Hydrometer Reading							
Battery # 3 Water Condition							
Battery # 4 Hydrometer Reading							
Battery # 4 Water condition							
Battery # 5 Hydrometer Reading							
Battery # 5 Water Condition							
Battery # 6 Hydrometer Reading							
Battery # 6 Water Condition							
Clean Battery Tops. Check Battery Cable and Terminal Condition							
NOTES:							
PAD CONDITION							
Pad		Good	Worn	Needs Replacement			
Pad retainer		Good	Worn	Needs Replacement			
Pad Holder Condition		Good	Worn	Needs Replacement			
CHECK OPERATION AND CONDITION OF:		IN SPEC	REPAIR	PROBLEM			
Key Switch							
Pad Pressure Adjustment							
Handlebar Switch							
Reverse Switch							
Burnish Switch							
Burnishing Deck Lift System							
Battery Charger Connectors							
Battery Charger							

Preventative maintenance records

CLEAN AND/OR LUBRICATE	IN SPEC	REPAIR	PROBLEM				
Burnishing Deck Linkage							
VISUALLY INSPECT:							
IN SPEC	REPAIR	PROBLEM					
Vacuum Motor Brushes							
Vacuum Hoses							
Brush skirts							
Pad Motor Brushes							
Pad Driver Condition							
Drive Wheel Condition							
Front Caster Condition							
All Rollers							
COMMENTS							
Technician's Name _____							
Technician's Signature _____		Date _____					
Customer's Name: _____							
Customer's Signature _____		Date _____					
©2006 R.P.S. Corporation							

Trouble Shooting

<u>Problem</u>	<u>Cause</u>	<u>Solution</u>
No power, nothing operates.	Faulty key switch. Batteries need charging. Faulty battery. Loose battery cable. Main circuit breaker tripped.	Contact local servicing dealer. See charging batteries. Replace battery. Tighten loose cable. Wait 5 minutes for auto reset. determine cause and correct.
Burnishing motor does not operate.	Burnishing deck is not down. Burnishing circuit breaker tripped. Carbon brushes worn. Faulty motor or wires.	Put deck down. Wait 5 minutes for auto reset Determine cause and correct. Contact local servicing dealer. Contact local servicing dealer.
Drive motor does not operate.	Recharge switch misadjusted. Faulty speed controller or wires. Faulty drive motor. Faulty wiring. Carbon brushes worn.	Contact local servicing dealer. Contact local servicing dealer. Contact local servicing dealer. Contact local servicing dealer. Contact local servicing dealer.
Drive motor runs incorrectly.	Faulty speed controller or wires. Faulty potentiometer. Loose wires.	Contact local servicing dealer. Contact local servicing dealer. Contact local servicing dealer.

Trouble Shooting

<u>Problem</u>	<u>Cause</u>	<u>Solution</u>
Poor dust control.	Main vacuum hose disconnected. Burnishing deck hose disconnected. Burnishing deck hose clogged. Damaged main vacuum hose. Damaged burnishing deck hose. Filter clogged. Filter door not closed tightly. Filter door gasket faulty. Filter full. Torn shroud curtain. Faulty vacuum Motor. Battery charge is low.	Reconnect hose. Reconnect hose. Remove debris. Contact local servicing dealer. Contact local servicing dealer. Clean out filters. Adjust screw on door clamp to tighten seal. Contact local servicing dealer. Remove debris. Contact local servicing dealer. Contact local servicing dealer. Charge batteries overnight.
Poor burnishing quality.	Burnishing pads worn out. Debris stuck to burnishing pad. Torn burnishing pad. Faulty disk pad motor. Battery charge is low.	Replace pads. Remove debris. Replace pads. Contact local servicing dealer. Charge batteries overnight.
Burnishing scrub deck noisy.	Missing burnishing pad. Burnishing pad worn out. Torn curtain hitting burnishing disks. Damaged shroud.	Replace pads. Replace pads. Contact local servicing dealer. Fix or replace shroud.
Rear tires noisy.	Bearings dry. Faulty hubs.	Grease bearings. Contact local servicing dealer.
Poor traction.	Excessive burnishing pad. Pressure. Worn drive tire.	Reduce pressure with switch. Contact local servicing dealer.
Short run time.	Batteries run down. Batteries still down. Batteries low on water. Batteries over cycled.	Charge batteries twice Contact local servicing dealer. Fill with distilled water to 3/4" above the lead plates. Contact local servicing dealer.

Battery Maintenance Guide

SAFETY:

- Always wear protective clothing, gloves and goggles when handling batteries
- If acid contacts your skin or eyes, flush with water immediately
- Keep flames, sparks and metal objects away from batteries
- Charge batteries in a well-ventilated area
- To avoid short circuits do not lay objects on top of battery
- Check that all cable connections to the terminal are properly tightened; connections that are too tight or too loose could result in post breakage, meltdown or fire

INSPECTION & CLEANING:

- Keep batteries clean and dry from residue
- Check that all vent caps are tight
- Use a solution of baking soda and water to clean if there is acid residue on batteries or corrosion on the terminals
- Protective spray or petroleum jelly should be applied to terminals to reduce corrosion

STORAGE:

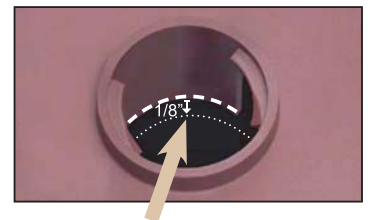
- Batteries should be fully charged prior to and during storage
- Never store discharged batteries
- Store batteries in a cool, dry place
- Recharge batteries before putting them back into service

WATERING:

- **ADD WATER, NEVER ACID, TO CELLS** (distilled water recommended)
- **DO NOT OVERWATER**
- Before charging the batteries, **only add water if the plates are exposed..** Add just enough water to cover the plates, then charge the batteries. Once fully charged, add water to the proper level as indicated below
- For fully charged **standard deep cycle batteries**, add water to level of 1/8" (3 mm) below bottom of vent well (see diagram A)
- For fully charged **Plus Series** batteries, add water to the maximum water level indicator (see diagram B)
- After watering, secure vent caps back on batteries

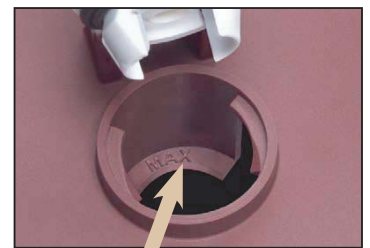


Diagram A



Add water to 1/8" (3 mm) below bottom of the vent well.

Diagram B



Add water to the maximum water level indicator.

Maximum Battery Size for Replacement

Pad Assist 185ah Batteries

Dimensions Inches (mm)		
Length	Width	Height
13 13/16"	7 1/8"	11 1/8"
(351)	(181)	(283)

Traction 185ah Batteries

Dimensions Inches (mm)		
Length	Width	Height
15 1/2"	7"	14 5/8"
(394)	(178)	(371)

Upgraded 245ah Batteries

Dimensions Inches (mm)		
Length	Width	Height
10 3/8"	7 1/8"	10 7/8"
(264)	(181)	(276)